

# UPCC

Bulletin SS02017 Issue/Rev. 0.3 (7/14)

## SMITH METER® UNIVERSAL PERFORMANCE CURVE COMPENSATOR

The Smith Meter® UPCC Universal Performance Curve Compensator is a microprocessor-based turbine meter preamplifier that has been designed to operate with the Smith line of multi-viscosity turbine meters. It is used to compensate for the viscosity of the product by either directly interfacing to a SolarTron Viscometer Head, by temperature inferred viscosity correction or current proportional to viscosity. It can also be used to convert the low voltage sinusoidal signal into a square wave pulse form that can be used to increase the transmission distance of the output.

The UPCC also functions as a flow computer that provides spontaneous and average flow rates, batch and cumulative totalization, and turbine meter frequency measurements. The pulse output can be raw uncompensated, a high resolution output, or quadrature for output only.

### FEATURES

- » **Electromagnetic Emissions:** EN 61000-6-3.
- » **Electromagnetic Immunity:** EN 55022.
- » **IEC 61000-4-2:** Electrostatic Discharge (ESD), Level 3+ (8.0 kV by contact, 12 kV by air).
- » **IEC 61000-4-3:** Radiated Electromagnetic Field, Level 3 (10 V/m).
- » **IEC 61000-4-4:** Electrical Fast Transient (Burst), Level 2 (1kV).
- » **IEC 61000-4-5:** Electrical High Energy Pulses (Surge), Installation Class 3, Criterion B.

**FMC**Technologies

**We put you first.  
And keep you ahead.**



**Universal Performance Curve Compensator**

### PRINCIPLE OF OPERATION

Viscosity and flow rate are key features in determining the performance of an MV Series Turbine Meter. By testing a meter over a range of viscosities and flow rates, the meter factor is determined and plotted relative to the log of velocity (flow rate)/viscosity. This data is also programmed in the UPC Compensator at the factory. Each meter has a unique meter factor vs. velocity/viscosity characteristic curve plotted over a specific flow and viscosity range. In actual operation, the product viscosity must be input for each product metered. The viscosity input can be:

- » **A Constant** – Manually input a known viscosity value. This is sufficient when the product viscosity varies little over the metered volume.
- » **Temperature/Viscosity Input** – The temperature/viscosity input is provided at minimum and maximum operating temperatures. The UPCC constantly reads the temperature and corrects for variations in viscosity. This increases the measurement accuracy when wide temperature variations are experienced.
- » **Viscometer Input** – An analog or digital input from an on-line viscometer. This may be necessary where a wide range of products are handled and programming product viscosities is not practical.

## SPECIFICATIONS

### Electrical Inputs

DC Power<sup>1</sup>

12 to 24 Vdc +/- 10%<sup>2</sup>

Switch: 5-36 Vdc

Current Consumption: Less than 250 mA at 24 volts

### Input Signal

Type: Sinusoidal, no DC offset

Sensitivity: 70 mVp-p at 25° C and 10 Hz

Frequency Range: 2000 Hz maximum

Mode: Single

Type: Square wave, no DC offset

Sensitivity: 24 Vp-p

Frequency Range: 2000 Hz maximum

### Input Impedance

10 k  $\Omega$  minimum at 20 Hz

### Status Inputs (3)

Type: One 4.7k  $\Omega$  resistor in series with isolator diode

Input Voltage Range: 4-36 Vdc

Pickup Voltage: 4 Vdc maximum

Dropout Voltage: 2 Vdc maximum

Current: 10 mA maximum

Common Mode: +/- 250 Vdc to chassis ground

Transient Protection: 39 volt Zener diodes

### Resistance (Temperature)

Type: Four-wire 100  $\Omega$  platinum resistance temperature detector (PRTD)

Temperature Coefficient at 32° F: 0.00214  $\Omega/\Omega/^\circ$  F (0.00385  $\Omega/\Omega/^\circ$  C)

Temperature Range: -148° F to 572° F (-100° C to 300° C)

Temperature Measurement Accuracy: Fluid temperature is measured to within +/- 0.72° F (+/- 0.4° C) over the fluid temperature range of -148° F to 572° F (-100° C to 300° C)

Fluid temperature is measured to within +/- 0.45° F (+/- 0.25° C) over the fluid temperature range of 32° F to 572° F (0° C to 300° C)

Stability: 0.1° F (0.06° C)/year

Self-calibrating: Lead length compensation that requires no resistance balancing of leads

### Analog (4-20mA)

Type: Two-wire, 4-20 mA current loop receiver, isolated from ground

Span Adjustment: Program adjustable through communications

Input Impedance: 50  $\Omega$

Accuracy: +/- 0.05% of range

Resolution: One part in 65,536

Voltage Drop: Two volts maximum

Sampling Rate: One sample / second minimum

### Electrical Outputs

#### Pulse Outputs

Type: Push-Pull driver (current sink or current source).

Two raw, two programmable

#### 12 Vdc input power supply:

No load: 7 Vp-p minimum square wave

270  $\Omega$  load: 4 Vp-p minimum square wave

#### 24 Vdc input power supply:

No load: 14 Vp-p minimum square wave

270  $\Omega$  load: 11 Vp-p minimum square wave

Sink Current: 240 mA at 24 Vdc maximum

Source Current: 80 mA at 24 Vdc maximum

Frequency Range: 0 to 2000 Hz at 50/50 duty cycle

### Switch Outputs

Type: Two open-collector transistors

Voltage Range: 6-36 Vdc

Sink Current: 240 mA at 24 Vdc maximum

Source Current: 80 mA at 24 Vdc maximum

Common Mode: +/- 250 Vdc to chassis ground

Transient Protection: 39 Volt Zener diodes across Darlingtons transistors

### Analog (4-20 mA)

Type: Two, two-wire, 4-20 mA current loop transmitters

Accuracy: +/- 0.25% of range

Resolution: One part in 65,536

Span Adjustment: Program adjustable through communications

## ENVIRONMENT

Ambient Operating Temperature: -58° F to 158° F (-50° C to 70° C)<sup>3</sup>

Ambient Storage Temperature: -58° F to 185° F (-50° C to 85° C)

Humidity: 0 to 95% non-condensing

1 DC power available from Smith Meter Electronics Instrumentation.

2 When used with the SolarTron Viscometer Head, the DC input power must be 24 Vdc.

3 For operation below -20° C, input power must be 24 Vdc.

## COMMUNICATIONS

### General

Configuration: Dip switch selectable between EIA-485 and EIA-232

Data Rates: Programmable to asynchronous data rates of 1200; 2400; 4800; 9600; or 19,200 bps.

Data Format: One start bit, one stop bit, programmable seven or eight data bits — even, odd, or no parity.

Data Structure: Modicon Modbus protocol with two modes of transmission (ASCII or RTU).

### EIA-232

Configuration: Three-wire (Tx, Rx, GND); non-multidrop.

Transient Protection: 60 V (bd) bidirectional transorbs across Tx and Rx lines; 1.5 kV maximum

### EIA-485

Configuration: Half duplex; jumper selectable

Termination: Dip switch selectable 120  $\Omega$  termination resistors of multidrop capabilities.

Transient Protection: 60 V (bd) bidirectional transorbs across Tx lines and across Rx lines, 1.5 kV maximum

### Approvals

#### Electrical

**UL/CUL, UL File E23545, Listed 557 N** - Class I Groups C and D; Class I, Zone I, Group IIB; Class I, Zone I, AExd IIB T6 IP66; UNL-UL ENCL. 4, CNL-CSA ENCL. 4; Tamb -50°C to 70°C.

**ATEX/IEC Ex** - PTB 10 ATEX 1039X / IEC Ex PTB 10.0052X – Ex d IIC T6 Tamb -40°C to 70°C IP66.

### Essential Health and Safety Requirements

**EN/IEC 60079-0:** Electrical apparatus for potentially explosive atmospheres – General requirements.

**EN/IEC 60079-1:** Electrical apparatus for potentially explosive atmospheres – Flameproof enclosures 'd'.

**EN 60529:** Degrees of protection provided by enclosures (IP code).

**EMC Compliance:** (by Council Directive 2004/108/EC).

**Electromagnetic Emissions:** EN 61000-6-3.

**Electromagnetic Immunity:** EN 55022.

**IEC 61000-4-2:** Electrostatic Discharge (ESD), Level 3+ (8.0 kV by contact, 12 kV by air).

**IEC 61000-4-3:** Radiated Electromagnetic Field, Level 3 (10 V/m).

**IEC 61000-4-4:** Electrical Fast Transient (Burst), Level 2 (1kV).

**IEC 61000-4-5:** Electrical High Energy Pulses (Surge), Installation Class 3, Criterion B.

### Signal Cable

Distance	Wire Size	Resistance/Foot
Up to 2400 ft. (731m)	#20 AWG	0.010150 chm/ft
Up to 3800 ft. (1158m)	#18 AWG	0.006385 chm/ft
Up to 6000 ft. (1828m)	#16 AWG	0.004016 chm/ft

**Note 1.** Cable loop resistance should be limited to 50  $\Omega$  maximum.

**Note 2.** Loop resistance = 2 times (cable length m/feet) times resistance in  $\Omega$ /foot of cable.

## UPCC MODELING

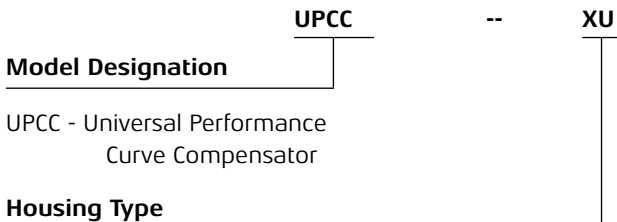

XU - UL/CUL Listed

XC - ATEX / IEC Ex Certified

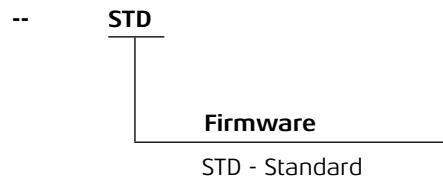

## TERMINAL CONNECTIONS

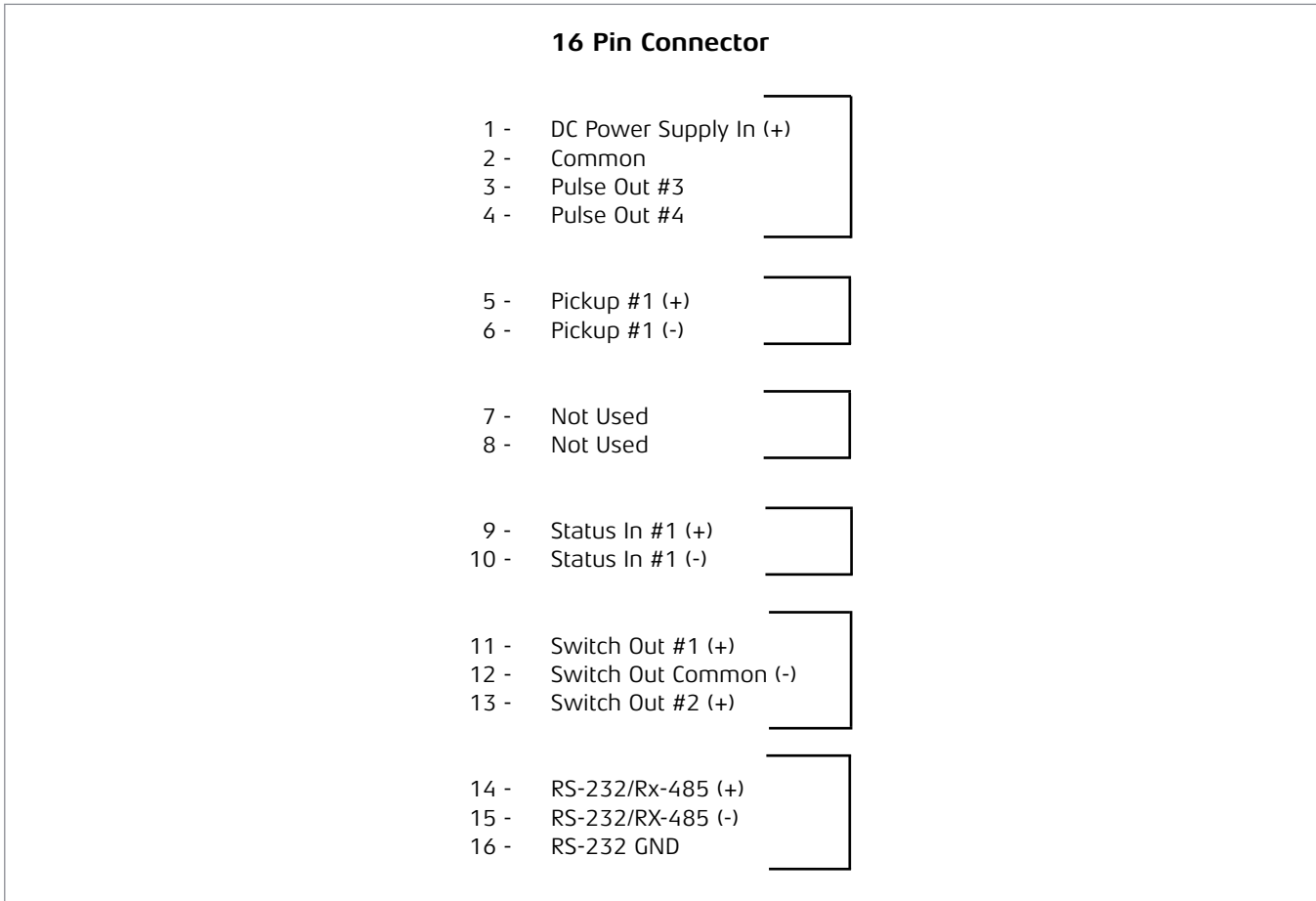

**Figure 1. Main Board**

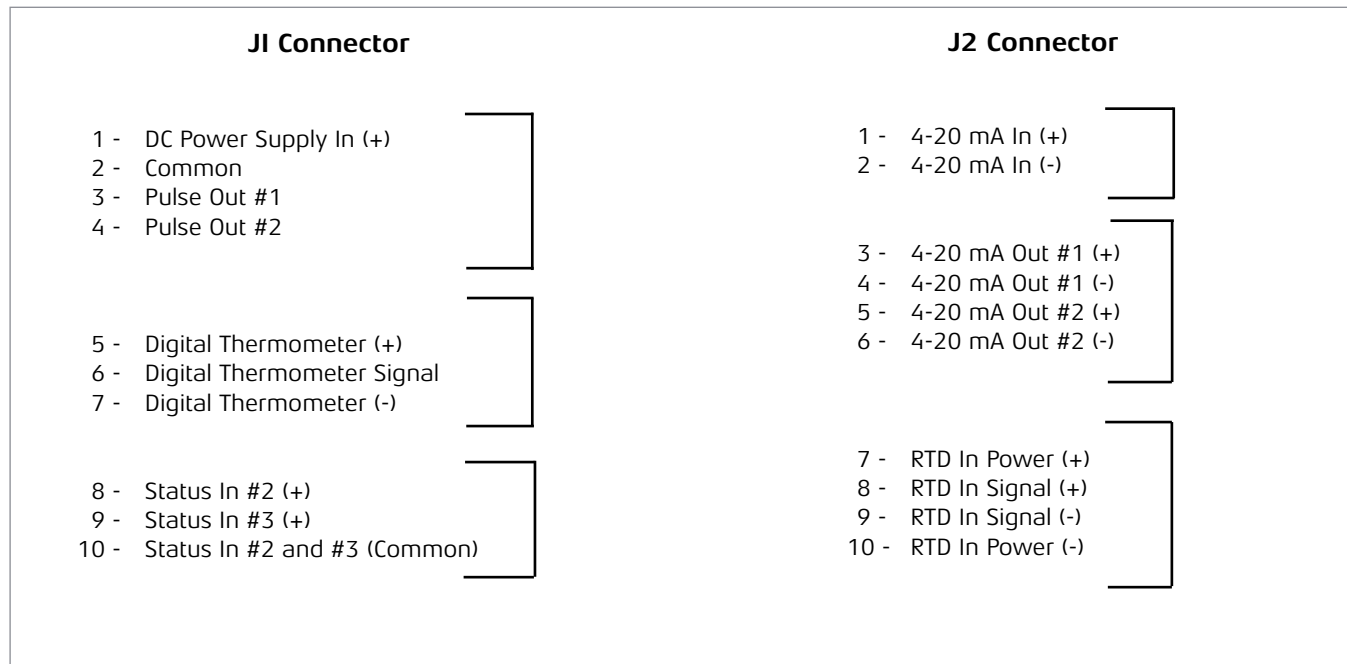

**Figure 2. Daughter Board**

# DIMENSIONS

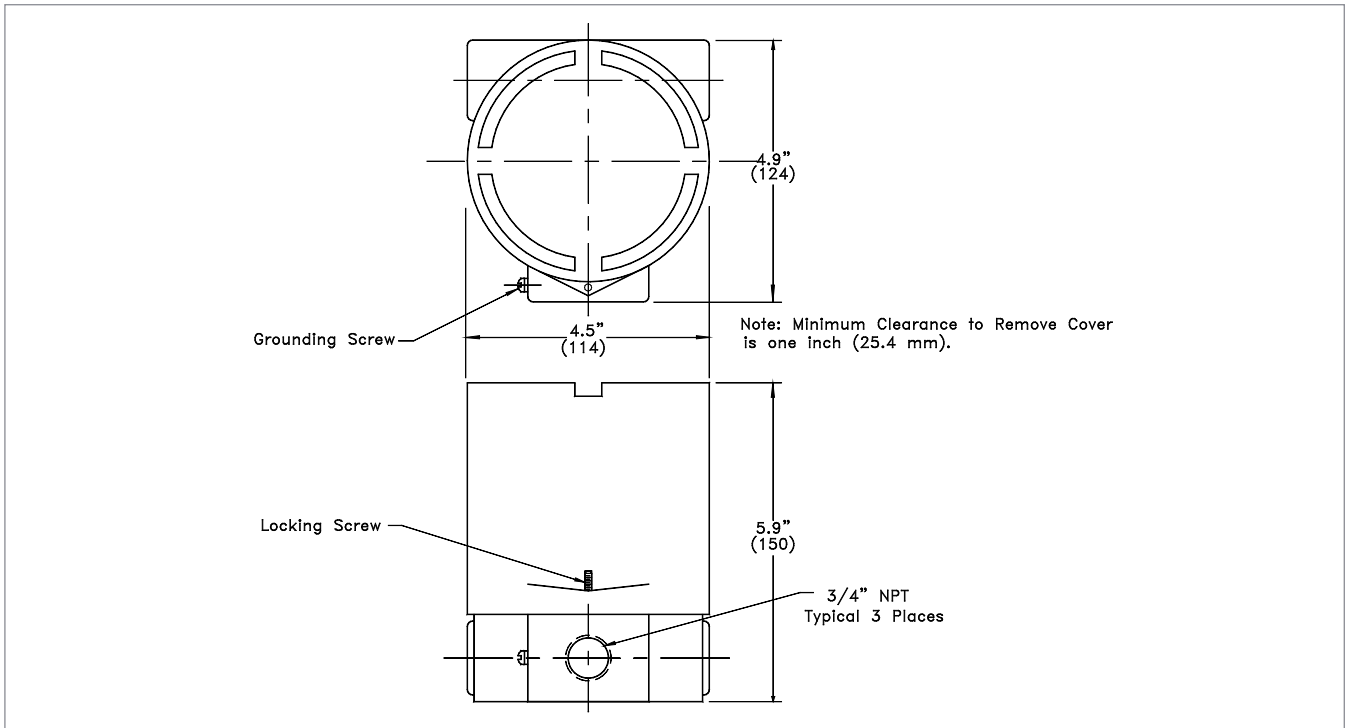

Figure 3. Housing Dimensions

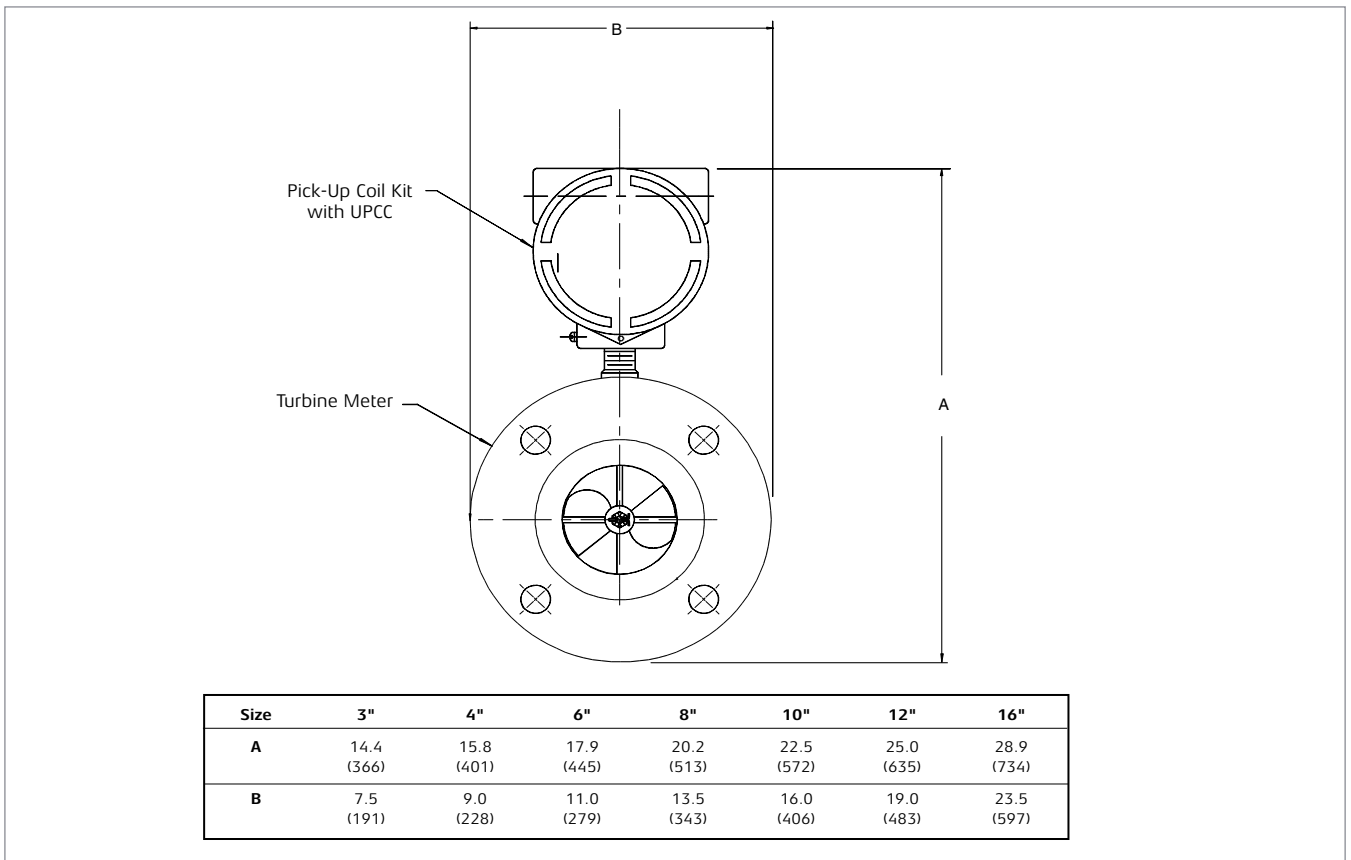

Figure 4. Factory-Mounted Envelope Dimensions for 150# Flanged Meter with Single Pickup Coil



**We put you first.  
And keep you ahead.**

**Revisions included in SS02017 Issue/Rev. 0.3 (7/14):**

Page 3: Approvals updated (ATEX / IEC Ex). Footnote 4 removed.

The specifications contained herein are subject to change without notice and any user of said specifications should verify from the manufacturer that the specifications are currently in effect. Otherwise, the manufacturer assumes no responsibility for the use of specifications which may have been changed and are no longer in effect.

Contact information is subject to change. For the most current contact information, visit our website at [www.fmctechnologies.com/measurementsolutions](http://www.fmctechnologies.com/measurementsolutions) and click on the "Contact Us" link in the left-hand column.